

CONTENITORI A FONDO APRIBILE CONTENITORI PORTA-ROTTAMI RIBALTABILI

CONTAINERS WITH OPENABLE BOTTOM
SCRAP DUMPING CONTAINERS

D



Tutte le misure del presente catalogo sono espresse in mm. e possono essere variate per esigenze tecniche senza preavviso.

All the measurements in this catalogue are in mm. and are subject to variation for technical reasons without forewarning.



Le dimensioni possono variare a richiesta
Dimensions may vary on request

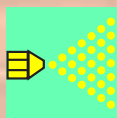

Verniciatura a polvere
Powder painting

Zincatura a caldo su richiesta
Hot-galvanizing on request

Gamma colori RAL • RAL colour range



6011



7000



2004



5010



5015

D Contenitori a fondo apribile

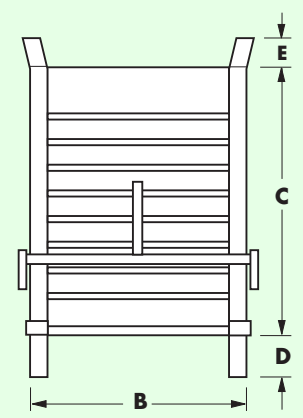
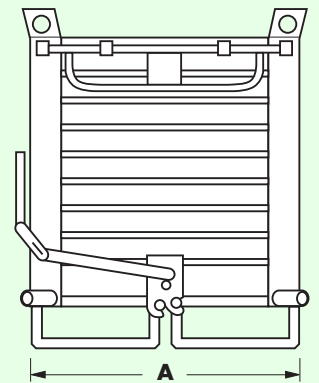
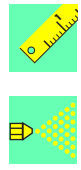

Modello Model	Dimensioni • Dimensions					Portata kg Capacity kg
	A	B	C	D	E	
SL-064-H650	1000	800	650	150	110	2000
SL-064-H1000	1000	800	1000	150	110	2000
SL-064-H1300	1000	800	1300	150	110	2000



h. 650

h. 1000

h. 1300

Containers with openable bottom D

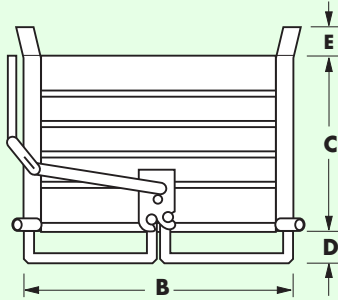
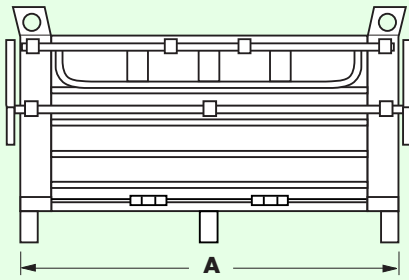

Modello Model	Dimensioni • Dimensions					Portata kg Capacity kg
	A	B	C	D	E	
SL-153-A	1500	1000	650	150	110	2000
SL-153-B	2000	1000	1000	150	110	2000

Fondo apribile - Unico fondello Openable bottom - Single base

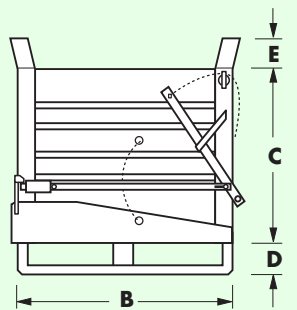
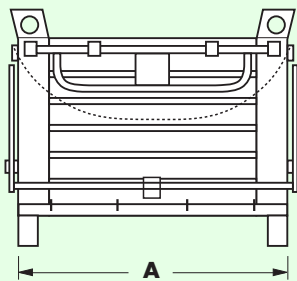

Modello Model	Dimensioni • Dimensions					Portata kg Capacity kg
	A	B	C	D	E	
SL-154-A	1000	800	650	150	110	2000
SL-154-B	1200	1000	650	150	110	2000

D Contenitori ribaltabili

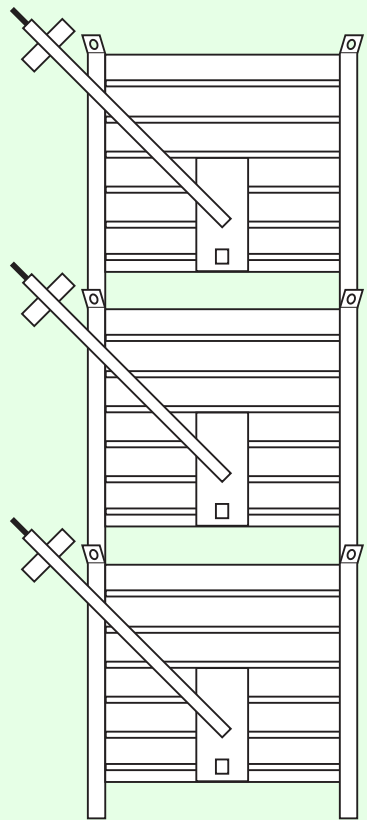
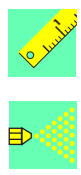

Modello Model	Dimensioni • Dimensions					Portata kg Capacity kg
	A	B	C	D	E	
SL-155-R	1000	1000	800	150	60	2000

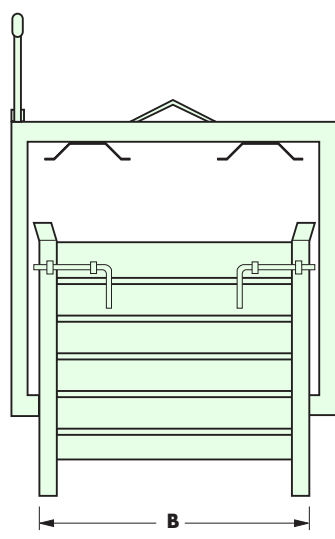

Contenitore
RIBALTABILE con
rotazione a 180° e
due ammortizzatori
in gomma per
assorbire gli urti del
ribaltamento

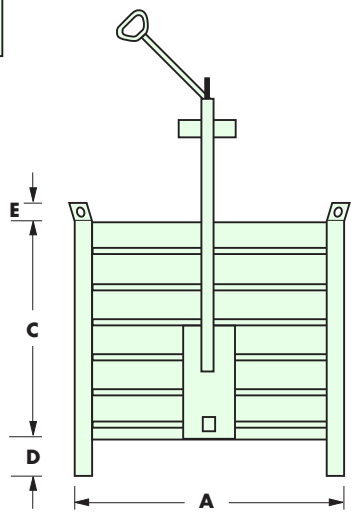

DUMPING container
with rotation
through 180° and
two rubber shock-
absorbers to absorb
the impact
of dumping





Modello Model	Dimensioni • Dimensions					Portata kg Capacity kg
	A	B	C	D	E	
SL-065-R	1000	800	500	130	60	800

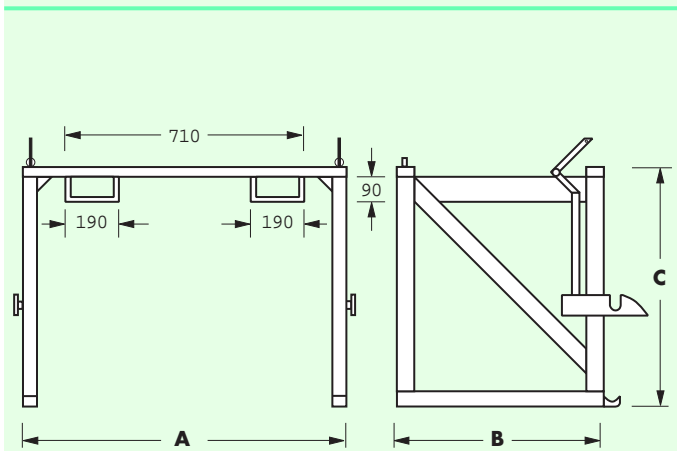
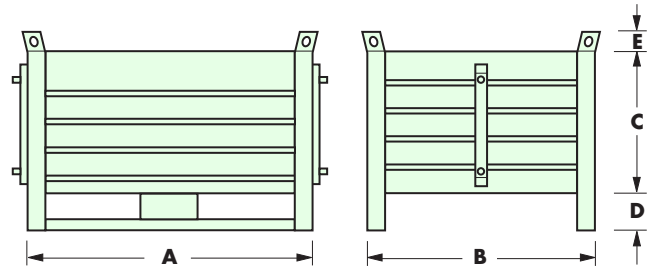

Modello Model	Dimensioni • Dimensions		
	A	B	C
Ribaltatore Dumping gear	1140	730	800

Ribaltatore per Mod. SL-065-R
Dumping gear for SL-065-R mod.



D Contenitori ribaltabili SL-066-R

Dumping containers SL-066-R

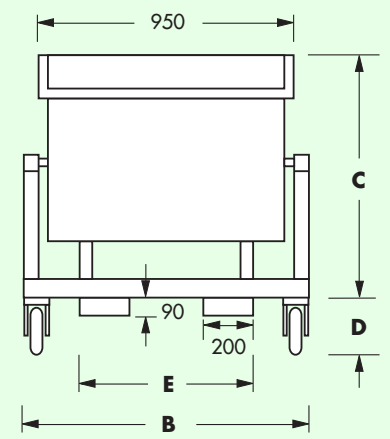
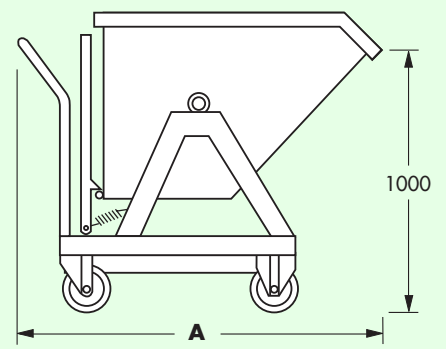
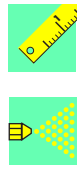

Completo di 4 ruote - 2 fisse e 2 piroettanti Ø 175 mm con vasca a tenuta stagna

Four-wheeled (2 fixed wheels plus 2 free wheels - Ø 175 mms). Supplied with sealed box.

Modello Model	Dimensioni • Dimensions					Portata Kg Capacity Kg
	A	B	C	D	E	
LT-450	1300	1050	910	200	620	1000



Benna ribaltabile in lamiera - *Dump bucket in sheet metal* **D**

- Idonea per merci sfuse di tutti i tipi
- Struttura particolarmente robusta
- Estremamente maneggevole
- Catena di sicurezza antiscivolo
- Azionamento di ribaltamento a mezzo fune
- Dispositivo di sicurezza contro ribaltamenti accidentali

- Suitable for loose goods of all types
- Especially robust structure
- Extremely handy
- Non-slip safety chain
- Dumping operation by means of rope
- Safety device against accidental dumping

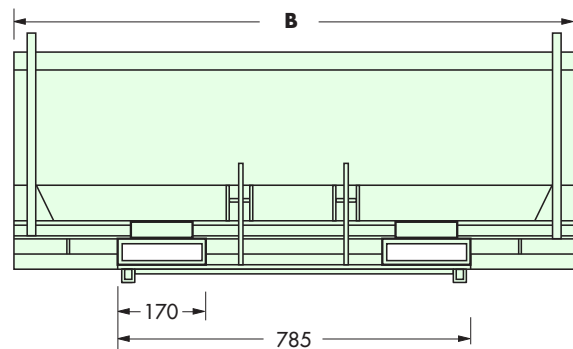
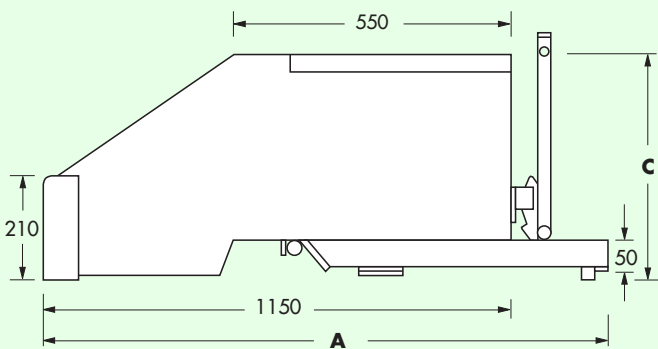

Modello Model	Dimensioni • Dimensions			Portata kg Capacity kg
	A	B	C	
SL/164/R	1380	1270	570	1000



D Contenitori porta-rottami ribaltabili SL-066-R

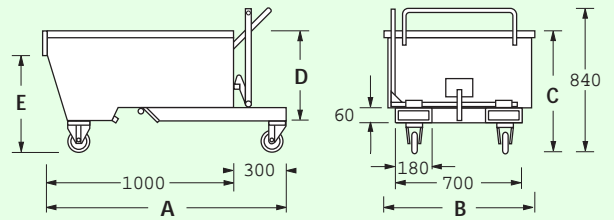

Modello Model	Dimensioni • Dimensions					Portata kg Capacity kg
	A	B	C	D	E	
LT-300	1300	820	650	490	530	600

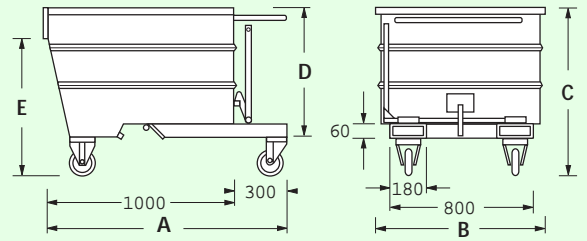

Modello Model	Dimensioni • Dimensions					Portata kg Capacity kg
	A	B	C	D	E	
LT-500	1300	920	910	700	750	1000

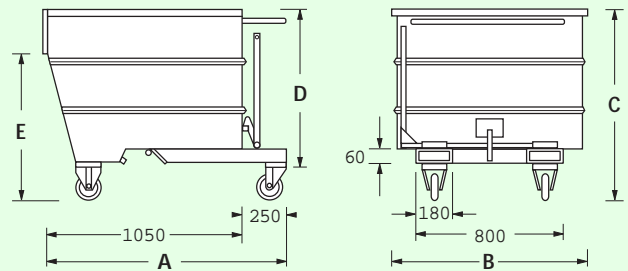

Modello Model	Dimensioni • Dimensions					Portata kg Capacity kg
	A	B	C	D	E	
LT-750	1300	1070	1030	830	800	1350

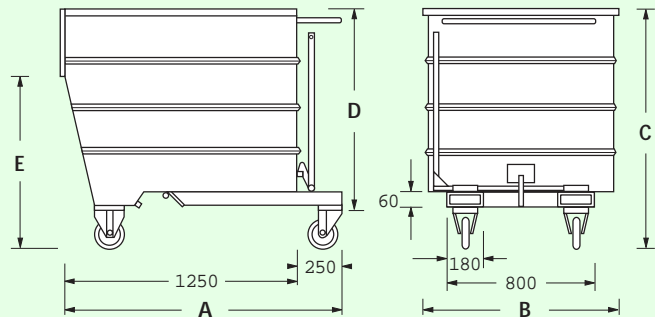

Modello Model	Dimensioni • Dimensions					Portata kg Capacity kg
	A	B	C	D	E	
LT-1000	1500	1070	1210	980	920	1700

Scrap dumping containers SL-066-R D

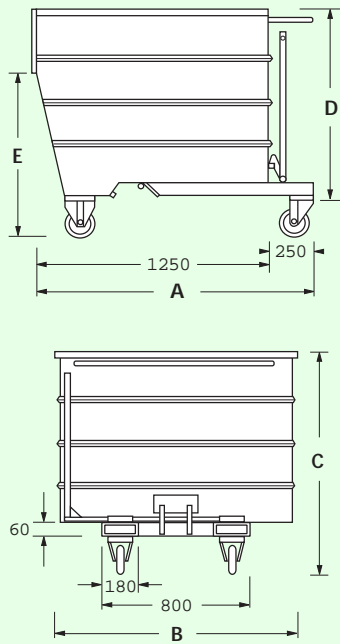

Scatole di inforcazione
Fork jackets

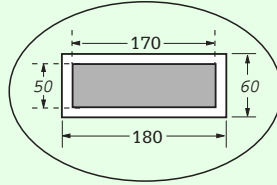

Sistemi movimentati studiati per facilitare la raccolta e lo scarico rifiuti, sfridi e rottami. Il problema della raccolta di rottami e gli sfridi di ogni genere in prossimità dei punti di lavoro, e del loro successivo scarico, viene risolto dalla SALL con una gamma di contenitori specifici espressamente studiati per un semplice e sicuro svuotamento automatico. Inforcabili con carrello elevatore, sono facilmente ribaltabili dall'operatore mediante una leva per svuotare completamente il contenuto senza scendere dal carrello. Si eliminano così le perdite di tempo ed i rischi di

infortuni propri di tutti gli altri sistemi manuali di raccolta e scarico dei rifiuti.

I contenitori porta-rottami ribaltabili SALL sono disponibili in una vasta gamma di modelli con portate differenziate, così da rispondere alle necessità di ogni tipo di azienda: carpenterie, rettifiche, fonderie, vetrerie, falegnamerie, cartotecniche, etc. Dotati di vasche a tenuta stagna, sono facilmente collocabili a mano in posizione di lavoro grazie a quattro ruote di grande diametro (due fisse e due piroettanti) montate su cuscinetti.

Mobile systems designed to facilitate waste and scrap collection and unloading operations. SALL solves the problem of collecting and unloading all types of scraps and wastes near work locations with a range of specific containers specially designed for simple and safe automatic emptying operations. Forkable with lift trucks, they can be easily tilted by the operator using a lever to empty the entire contents without ever getting off the vehicle. This avoids wasting time and prevents accidents that occur with other manual waste collection and unloading systems. The SALL tipping scrap containers are available in a wide range of models with various capacities, thus meeting the requirements of all types of companies: carpentry, joinery and grinding shops, foundries, glassworks, paper mills, etc. Equipped with watertight tanks, they can be easily moved by hand into the work position thanks to four large-diameter wheels (two fixed and two pivoting) mounted on bearings.

Modello Model	Dimensioni • Dimensions					Portata Kg Capacity Kg
	A	B	C	D	E	
LT-1350	1500	1320	1210	980	920	2000



D

A richiesta tutti i portarottami mod. SL/066/R sono disponibili con:

On request, all the scrap containers model SL/066/R can be supplied with:



Valvola regolabile limitatrice di flusso
Adjustable flow limiter valve

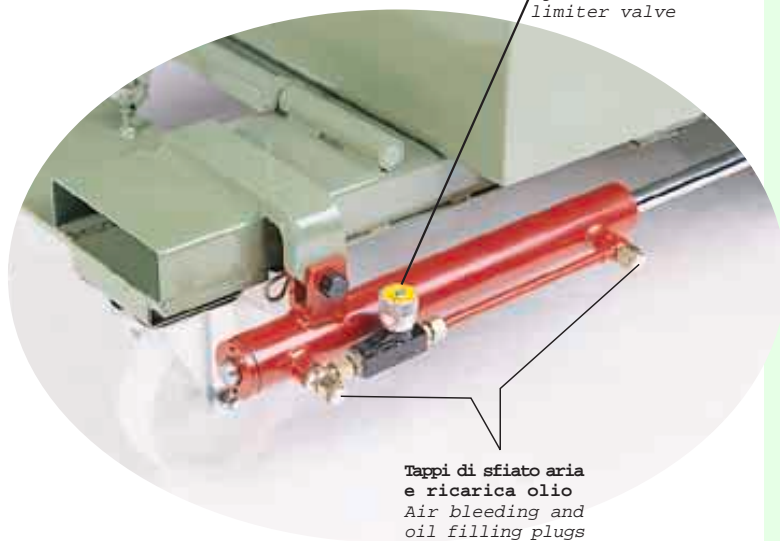

Tappi di sfiato aria e ricarica olio
Air bleeding and oil filling plugs



- Vasca di decantazione e rubinetto a sfera per separare le sostanze liquide da quelle solide.
- Setting tank and ball valve to separate liquid and solid substances.

- Impianto idraulico autonomo: cilindro idraulico a doppio effetto, con valvola regolabile limitatrice di flusso, che permette un graduale ribaltamento del portarottami.
- Independent hydraulic plant: two-stage hydraulic cylinder, with adjustable flow limiter valve, that allows the scrap container to tip gradually.

Coperchio in lamiera incernierato sdoppiabile a metà.

Centrally split hinged metal sheet cover.

